

CSE 5526 - Autumn 2014
Introduction to Neural Networks

Homework #2

Due Tuesday, Sept. 16

Grader: Yuzhou Liu
 Email: liu.2376@osu.edu
 Office: Dreese Labs 578
 Office hours: Monday & Wednesday 3 - 4pm

Problem 1. (a) For the following training samples:

$$\mathbf{x}_1 = (0, 0)^T \in C_1$$

$$\mathbf{x}_2 = (0, 1)^T \in C_1$$

$$\mathbf{x}_3 = (1, 0)^T \in C_2$$

$$\mathbf{x}_4 = (1, 1)^T \in C_2$$

Plot them in input space. Apply the perceptron learning rule to the above samples one-at-a-time to obtain weights that separate the training samples. Set η to 0.5. Work in the space with the bias as another input element. Use $\mathbf{w}(0) = (0, 0, 0)^T$. Write the expression for the resulting decision boundary.

(b) XOR. For $\mathbf{x}_2, \mathbf{x}_3 \in C_1$ and $\mathbf{x}_1, \mathbf{x}_4 \in C_2$, describe your observation when you apply the perceptron learning rule following the same procedure as in (a).

Problem 2. The following figure shows the decision regions of four classes. Design a classifier for these linearly inseparable classes, using a network of M-P neurons with three output units. For class i ($1 \leq i \leq 3$), classification requires that $y_i = 1$, with $y_j = -1$ for $j \neq i$. Class 4 is recognized when $y_i = -1$ for $1 \leq i \leq 3$. (HINT: try a two-layer feedforward network.)

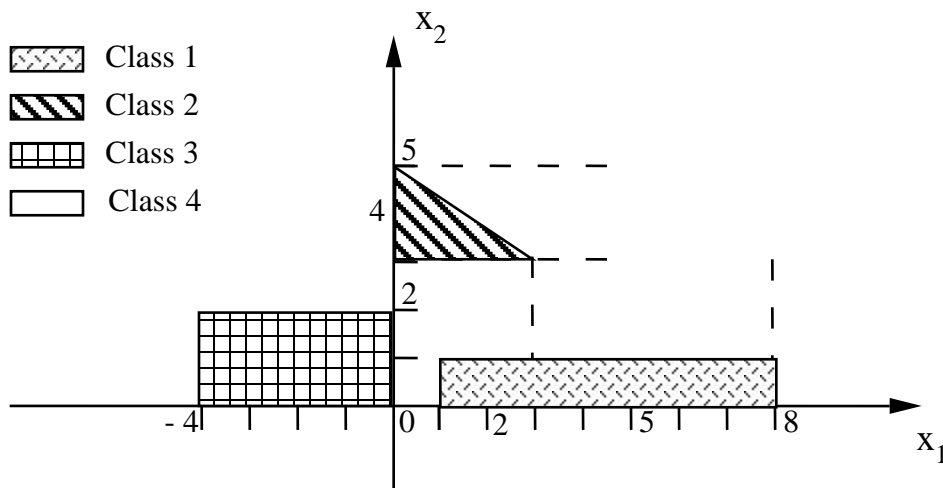

Problem 3. Given the following input points and corresponding desired outputs:

$$X = \{-0.5, -0.2, -0.1, 0.3, 0.4, 0.5, 0.7\}$$

$$D = \{-1, 1, 2, 3.2, 3.5, 5, 6\}$$

write down the linear regression squared error cost function with respect to w (setting the bias to zero). Compute the gradient with respect to w at the point $w = 2$ using both direct differentiation and the LMS approximation (averaged over all data samples in both cases), and see if they agree.